

Product: 1495 TSW 1,5

Image



Description

TSW 1,5
5 STEP TRANSFORMER CONTROLLER
1 PH, 230 V, 1.5 A

Speed controller transformer with on-off switch for speed controlling of one or more fans with the use of a voltage reducer, five step switch, for surface installation. Housing protected in accordance to IP 20. Voltages 0/80/130/170/230 V, 50/60 Hz.

Wiring diagram

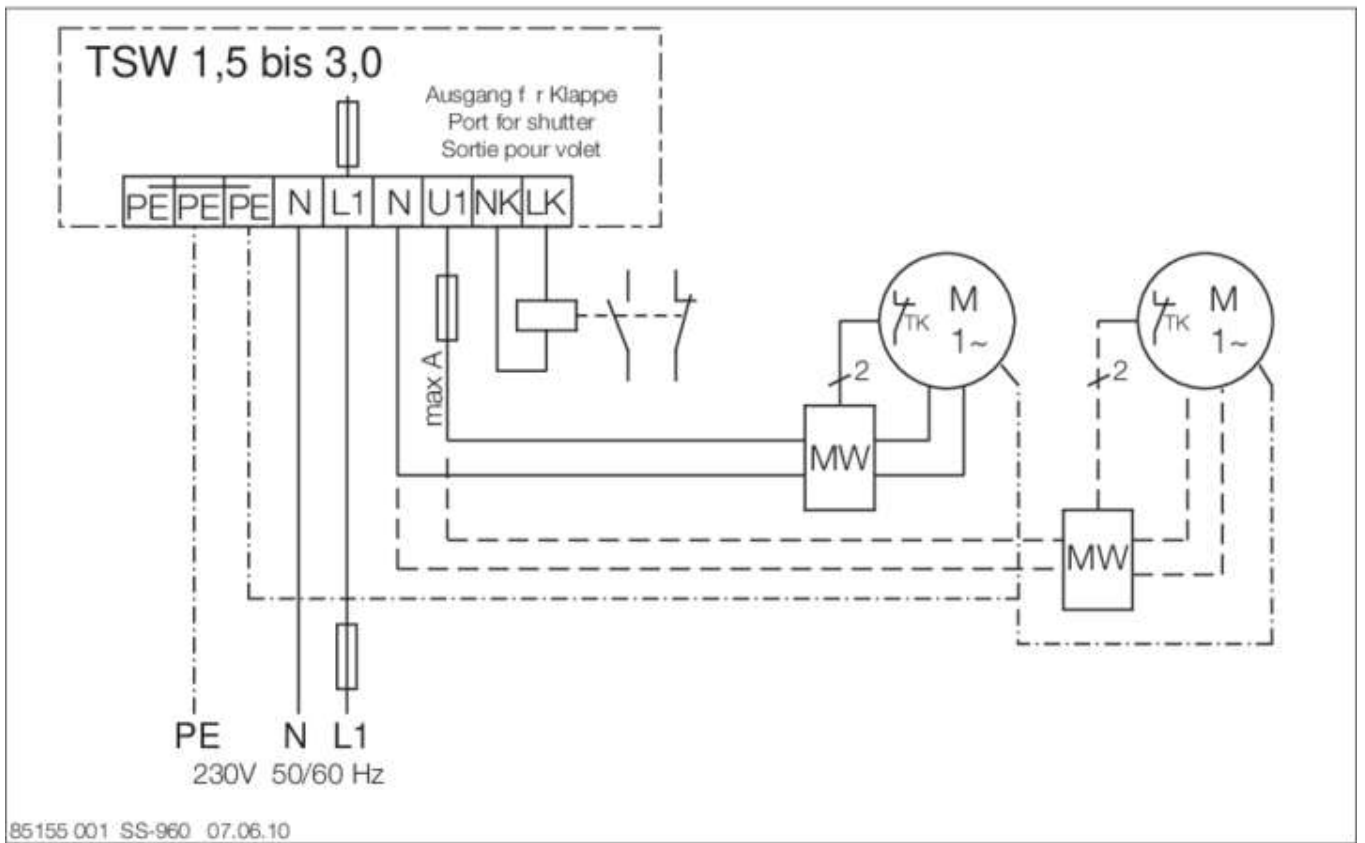

Dimensions

