

CA MD E W RANGE

Steel sheet mixed flow wall fans

Steel sheet mixed flow wall fans. Installed at the end of the ventilation duct, effectively meet the ventilation needs of commercial or industrial premises (laboratories, bars, restaurants, laundries, gyms, etc.).

VERSIONS

8 models, with nominal diameter between 100 and 315 mm.

KEY FEATURES

- Built to withstand weathering and high temperatures.
- Extremely reliable and low maintenance.
- Wide continuous operation temperature range.
- Fully compliant with Reg. ErP 2018 N. 1253/2014.

TECHNICAL FEATURES

- Pickled, phosphate-coated steel sheet casing and wall fixing plates that have been painted with polyester paint against aggressive weathering.
- Motor-holder built into the boxes housing the mains connection terminals and the flow conditioner fins, constructed in self-extinguishing plastic resin (V0).
- 3-speed fans that can be set using optional device TRIO-CA (code 12869), composed of:
 - AC motors with thermal overload cut-out and shafts turning on ball bearings to guarantee long lasting continuous service (at least 30,000 h) at the maximum plate temperature.
 - Backward-curve, heat resistant plastic resin blade impellers loaded with glass fibre to combine structural strength and dimensional stability.
- Possibility of connecting to remote environmental temperature, humidity, smoke and presence sensors (optional).
- Performance and safety certified by third party body (IMQ).
- Protection rating from the water: IP44 (appliance ducted in extraction and delivery).
- Insulation Class: II .



TECHNICAL DATA

Models	Code	V~50/60	Max Airflow			Max Pressure		LP DB(A) 3m*	Max °C	KG		
			W min/med/max	A min/med/max	RPM min/med/max	m³/h min/med/max	l/s min/med/max				mmH₂O min/med/max	Pa min/med/max
CA 100 MDEW	16120	220-240	25 24 85	0,13 0,18 0,23	970 1650 2450	160 262 400	44,4 72,7 111,1	26,8 38,8 38,8	262,2 380,1 380,1	19,2 - 35,7	50	3,7
CA 125 MDEW	16121	220-240	25 24 85	0,13 0,18 0,23	935 1660 2445	160 295 445	44,4 81,9 123,6	13,9 34,5 36,2	136,5 338,0 355,9	25,5 - 39,4	50	3,8
CA 150 Q MDEW	16122	220-240	25 24 85	0,13 0,18 0,23	965 1615 2435	168 295 455	46,6 81,9 126,3	7,1 21 32,5	69,5 206,0 318,7	28,3 - 38	50	4,8
CA 150 MD E W	16133	220-240	39 50 85	0,34 0,35 0,38	1740 2230 2690	400 510 617	111,1 141,6 171,3	31,6 40,0 43,8	310,4 392,6 429,7	41,4 - 53,3	55	4,8
CA 160 MD E W	16134	220-240	38 50 85	0,35 0,35 0,38	1570 2120 2680	385,8 515 665	107,1 143 184,7	28 37,8 42,4	275,1 370,8 416,7	43 - 53	55	6,2
CA 200 MD E W	16135	220-240	39 50 90	0,35 0,35 0,40	1455 1960 2630	455 635 825	126,3 176,3 229,1	34,3 42,2 44	337,1 413,6 432,3	37,9 - 48,2	55	6
CA 250 MD E W	16136	220-240	48 79 130	0,48 0,57 0,55	1340 2015 2675	500 760 1030	138,8 211,1 286,1	34,9 52,8 55,9	342,3 518,4 548,3	31,6 - 50,8	50	6,2
CA 315 MD E W	16137	220-240	48 79 120	0,48 0,57 0,55	1335 2020 2670	490 765 1030	136,1 212,5 286,1	35,7 54,5 58,2	350,5 534,8 570,8	41,2 - 51,4	50	9,4

* Sound pressure level measured at 3 m in free field conditions with long-cased appliance in delivery mode in accordance with standard EN ISO 9614.

ENERGY DATA FOR REGULATION N° 1254/2014/UE

	UNIT OF MEASURE	CA 100 MDEW	CA 125 MDEW	CA 150 Q MDEW	CA 150 MDEW
CODE		16120	16121	16122	16133
Supplier's name or trade mark	-	Vortice	Vortice	Vortice	Vortice
SFPint	W(m³/s)	NA*	NA*	NA*	NA*
Declared typology	-	NRVU-U**	NRVU-U**	NRVU-U**	NRVU-U**
Type of drive	-	MSD***	MSD***	MSD***	MSD***
Type of heat recovery system HRS	-	None	None	None	None
Nominal NRVU flow rate	m³/s	0,10994	0,12206	0,12328	0,17025
Effective electric power input	kW	0,050	0,050	0,050	0,081
Face velocity at design flow rate	m/s	13,99856	9,94598	6,97610	9,63418
Nominal external pressure (Δps, ext)	Pa	88	108	137	59
Internal pressure drop of ventilation components (Δps,int)	Pa	44	-6	-40	171
Internal pressure drop of non-ventilation components (Δps,add)	Pa	0	0	0	0
Static efficiency of fans used in accordance with Regulation (EU) N. 327/2011	%	29,0	24,9	23,9	48,2
Declared maximum internal leakage rate of the casing of ventilation units	%	NA*	NA*	NA*	NA*
Declared maximum external leakage rate of the casing of ventilation units	%	NA*	NA*	NA*	NA*
Energy performance energy or classification of the filters	-	NA*	NA*	NA*	NA*
Description of visual filter warning	-	NA*	NA*	NA*	NA*
Casing sound power level	LWA[dB(A)]	36	39	38	53

*NA: Not applicable - **RVU-U: Non Residential Ventilation Unit - Unidirectional - ***MSD: Multi-Speed Drive



COMMERCIAL VENTILATION

CA MD E W RANGE

ENERGY DATA FOR REGULATION N° 1254/2014/UE

CODE	UNIT OF MEASURE	CA 160 MD E W	CA 200 MD E W	CA 250 MD E W	CA 315 MD E W
Supplier's name or trade mark	-	Vortice	Vortice	Vortice	Vortice
SFPint	W(m³/s)	NA*	NA*	NA*	NA*
Declared typology	-	NRVU-U**	NRVU-U**	NRVU-U**	NRVU-U**
Type of drive	-	MSD***	MSD***	MSD***	MSD***
Type of heat recovery system HRS	-	None	None	None	None
Nominal NRVU flow rate	m³/s	0,18356	0,22633	0,28222	0,28083
Effective electric power input	kW	0,083	0,088	0,127	0,127
Face velocity at design flow rate	m/s	9,12931	7,20442	5,74939	3,60361
Nominal external pressure (Δp_s , ext)	Pa	49	128	108	128
Internal pressure drop of ventilation components (Δp_s ,int)	Pa	158	-16	25	8
Internal pressure drop of non-ventilation components (Δp_s ,add)	Pa	0	0	0	0
Static efficiency of fans used in accordance with Regulation (EU) N. 327/2011	%	45,9	28,7	29,6	30,0
Declared maximum internal leakage rate of the casing of ventilation units	%	NA*	NA*	NA*	NA*
Declared maximum external leakage rate of the casing of ventilation units	%	NA*	NA*	NA*	NA*
Energy performance energy or classification of the filters	-	NA*	NA*	NA*	NA*
Description of visual filter warning	-	NA*	NA*	NA*	NA*
Casing sound power level	LWA[dB(A)]	53	48	51	51

*NA: Not applicable - **RVU-U: Non Residential Ventilation Unit - Unidirectional - ***MSD: Multi-Speed Drive





DIMENSIONS

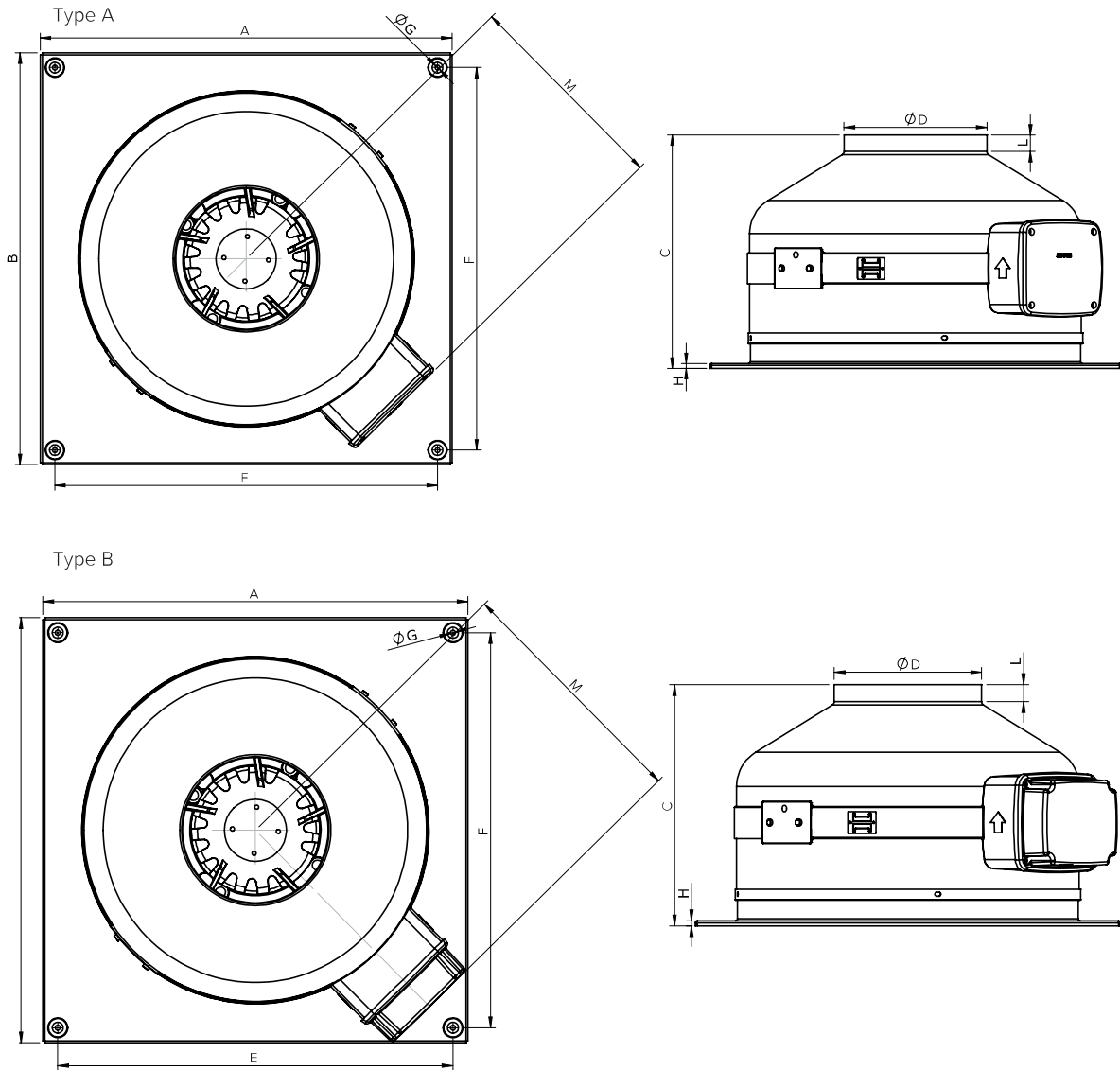

MODELS	TYPE	ØA	B	C	ØD	E	F	G	H	L	M
CA 100 MDEW	B	334	334	210	97	304	304	5	5	15	198
CA 125 MDEW	B	334	334	210	122	304	304	5	5	23	198
CA 150 Q MDEW	B	334	334	210	147	304	304	5	5	30	198
CA 150 MDEW	A	424	424	245	147	394	394	5	5	17	220
CA 160 MDEW	A	424	424	245	157	394	394	5	5	18	220
CA 200 MDEW	A	424	424	245	197	394	394	5	5	20	220
CA 250 MDEW	B	424	424	237	247	394	394	5	5	38	250
CA 315 MDEW	A	489	489	260	312	459	459	5	5	36	252

Dimensions (mm)



COMMERCIAL VENTILATION

CA MD E W RANGE

PERFORMANCES CURVES

CA 100 MD E W

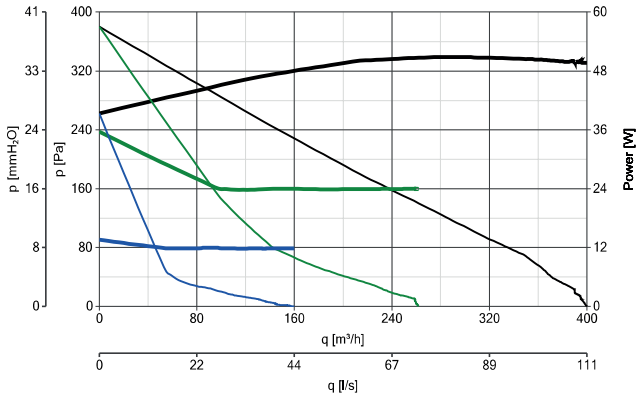

CA 125 MD E W

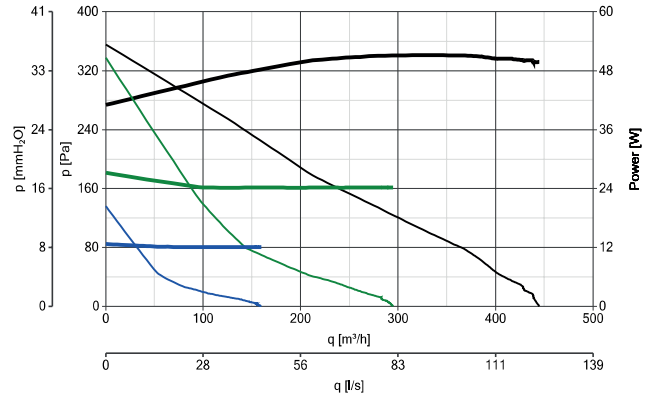

CA 150 Q MD E W

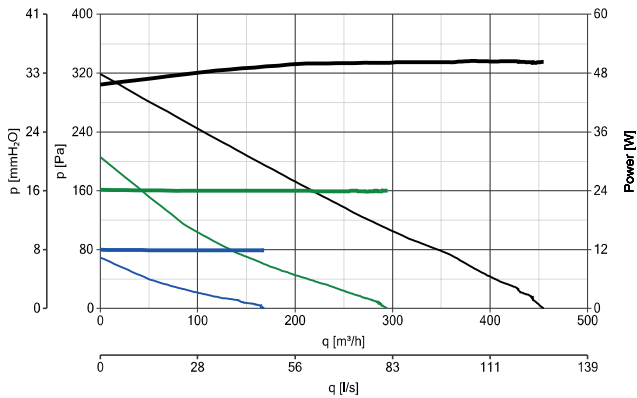

CA 150 MD E W

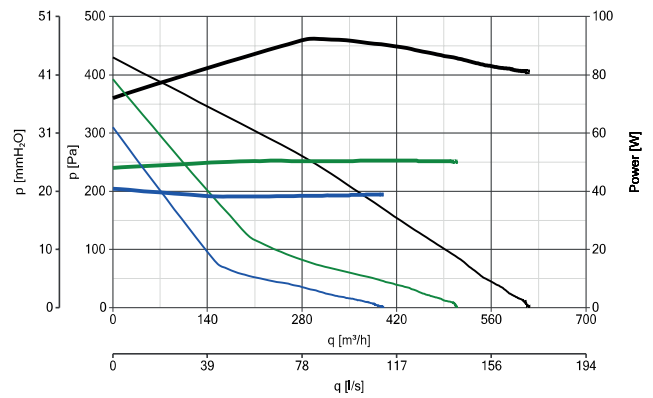

CA 160 MD E W

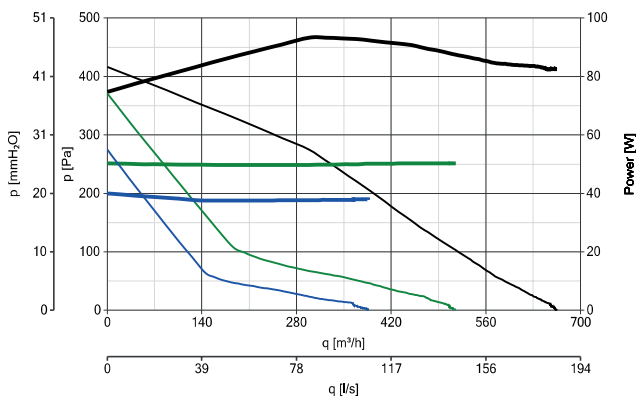

CA 200 MD E W

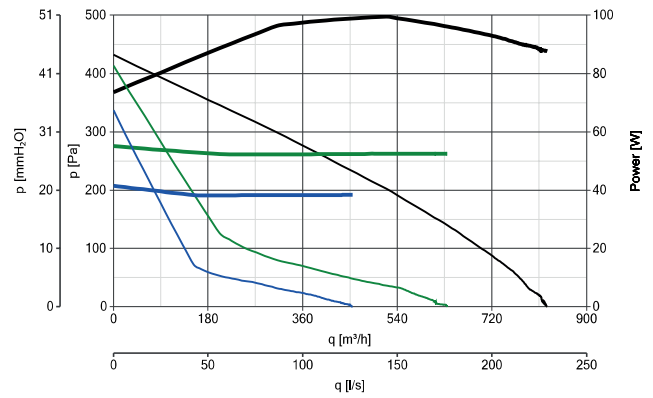

POWER CONSUMPTION
 — max
 — med
 — min



PERFORMANCE CURVES
 — max
 — med
 — min

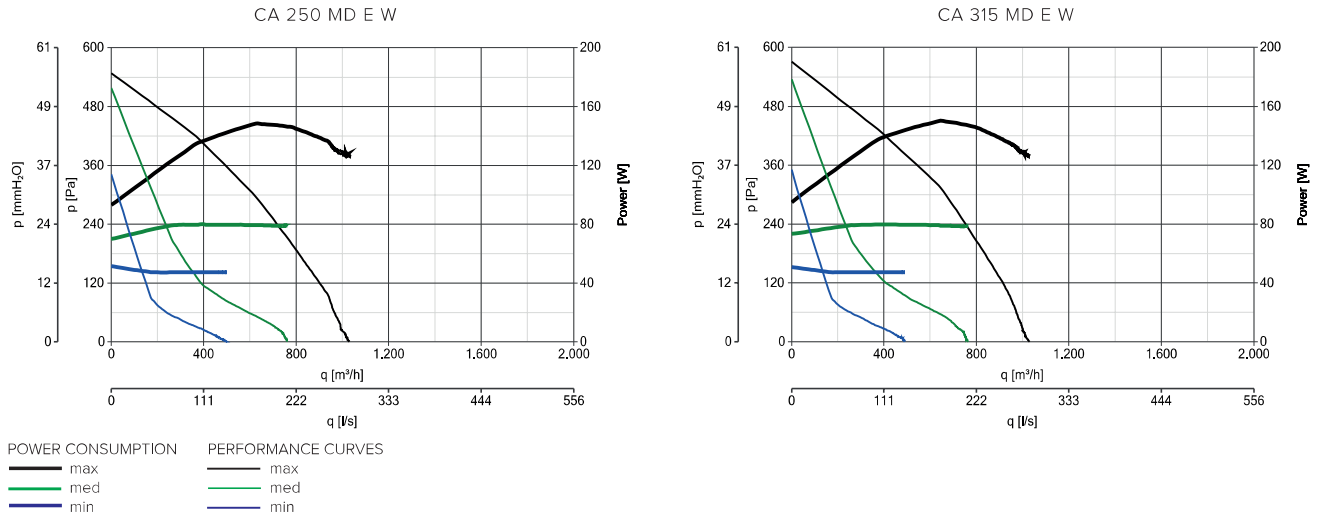

PERFORMANCES CURVES



CONTROLLERS

MODELS	DESCRIPTION	CODE	PRODUCT
	C 1.5 - ELECTRONIC SPEED CONTROLLER 1.5 A	12966	ALL PRODUCTS
	C 2.5 - ELECTRONIC SPEED CONTROLLER 2.5 A	12967	ALL PRODUCTS
	KIT SCB - BUILT-IN CONTROLLER ADAPTOR	22481	12966 - 12967
	TRIO - 3 SPEED SWITCH FOR WALL AND FLUSH MOUNTING INSIDE UNI 503 STANDARD ELECTRIC BOXES	12869	ALL PRODUCTS

ACCESSORIES ON REQUEST

MODELS	DESCRIPTION	CODE	PRODUCT
		100	22750
		125	22755
		150	22760
		160	22762
		200	22765
		250	22770
		315	22775
	CA-G - PROTECTION GRILLE	16120	16121
		16122 - 16133	16134
		16135	16136
		16137	